

Peak Playbook

The small business essential guide to the busy season



Australia Post

A note from Gary Starr

As we gear up for another peak season, eCommerce businesses like yours are faced with a mix of challenges and opportunities. While cost-of-living pressures are still top of mind, online shopping is proving resilient. In fact, eCommerce is on an upward trend in Australia and we're expecting a robust peak season.

To help you make the most of it, we've put together this playbook which covers:

1

Exclusive insights: The latest eCommerce and economic trends to help you make informed decisions.

2

Back to basics: A refresher on the essentials from parcel preparation and sending to tracking and delivery options.

3

Key details: Where to find the latest updates on our delivery changes, forecasting peak volumes and self-serve resources.

We look forward to working together to make this your most successful peak yet.

All the best,

Gary Starr

**Executive General Manager,
Parcel, Post & eCommerce Services**





SellerDash is partnering with Australia Post to bring you our insights and tips for a successful peak season.

The Sellerdash forecast

We expect this peak to be even larger than 2023 so planning sales events well in advance will help ensure you're ready to meet the increased demand and maximise your success.

Customers will be even more deal-conscious this peak, actively seeking out the best offers and making the most of extended sales periods. To capitalise on this, create compelling deals and promotions that stand out in a crowded market.

Also make sure you have efficient shipping processes in place to handle higher sales volumes and get orders out quickly to maintain customer satisfaction.

Top tips from Sellerdash

- ✓ **Optimise your shipping workflows** for timely dispatch of products and minimal delays.
- ✓ **Accurately forecast sales and stock up on popular products and necessary warehouse supplies.** This will help you maximise peak demand and avoid customer disappointment due to stock shortages.
- ✓ **Ensure your team is well-equipped to manage the higher volume of orders.** Accurate picking and packing help maintain efficiency, avoid errors and reduce returns. Proper preparation now will save time in the long run.

Partner with SellerDash to streamline your shipping processes.
Start your 7-day free trial today.



Contents

Part 1

Delivering for your best peak ever



Data-driven insights to help you plan for a strong peak

Customer loyalty lies in delivery speed

Boost parcel sending efficiency

Part 2

Nailing the basics



Smart prep for smooth processing

Streamlining your deliveries

Hassle-free returns

International sending at your fingertips

A positive delivery experience

Part 3

The essentials



How we're delivering for your business this peak

Forecasting and preparing for peak season volumes

Self-serve resources and FAQs

Simplifying eCommerce speak

Delivering for your best peak ever

Make the right call with
data-driven insights



Data insights to help you

plan for a strong peak

Data is a powerful tool for predicting online shopping trends and refining your eCommerce strategy. Use our latest [eCommerce update](#)¹ to inform your approach to peak season and beyond.

Online purchases grew by:

1.1%

YoY

+2.1%

QoQ

+2.0%

in the last 12 months
leading up to June 2024

+4.4%

YOY in End of Financial Year
(EOFY) sales growth

Most popular categories:



How the states performed:

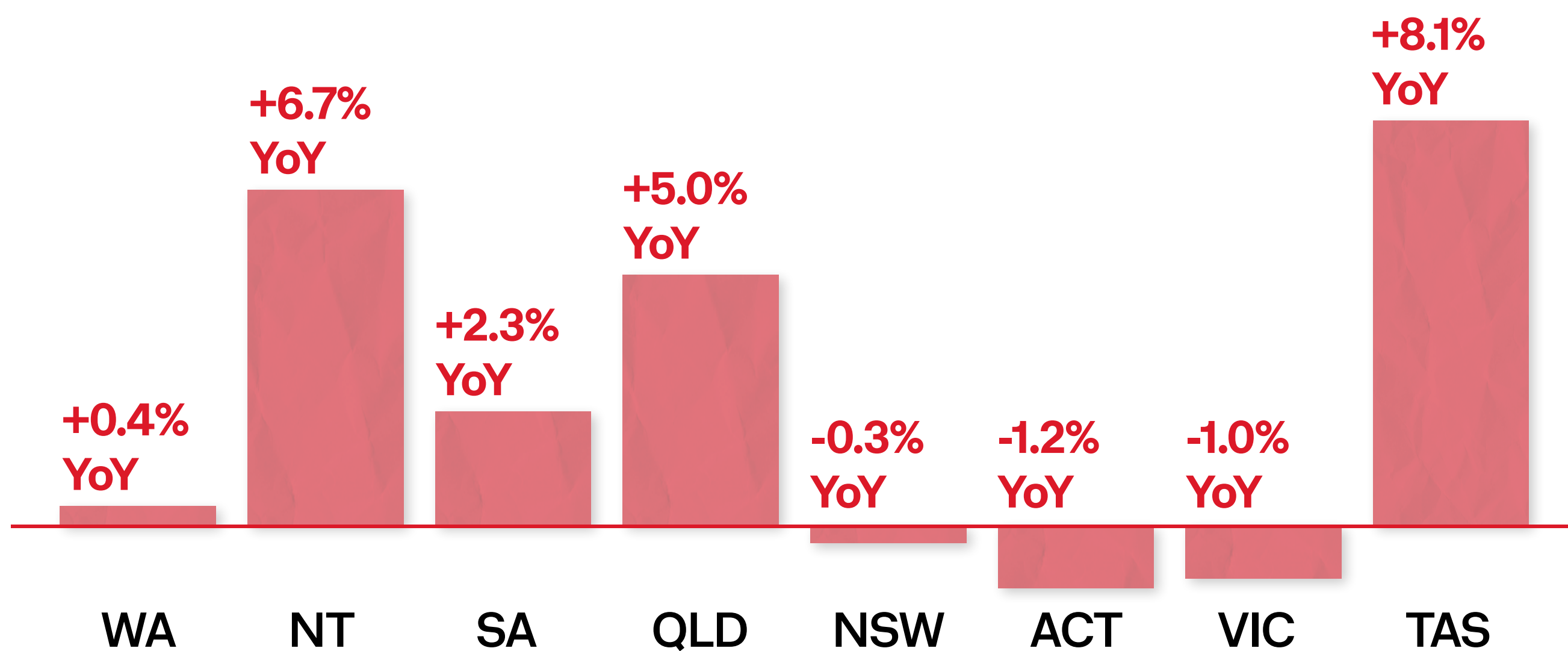

Here's how these insights can help strengthen your peak strategy

Tailor your marketing campaigns to target regions showing strong growth, such as Queensland, Tasmania and regional Australia.

Bundle products or offer discounts to attract customers looking for cost-effective options.

Provide flexible payment options like buy now, pay later (BNPL) services to make products more accessible.

Focus on retention (usually more cost-effective than acquisition) by offering loyalty rewards, exclusive discounts or early access to sales. Nearly half of online purchases in FY24 were from sites that people have a loyalty/membership relationship with.¹

eCommerce

18% Regional
16% Metro

Regional eCommerce growth has outpaced metro by 2% since 2019.²



Set your business up for Black Friday success with our [list of strategy ideas](#).



“Despite the cost-of-living challenges, eCommerce in Australia is proving resilient. We've seen growth in EOFY and Click Frenzy sales this year, and we expect a robust peak season.

– Phillip Ngo, Strategic Insights Lead at Australia Post

Customer loyalty lies

in delivery speed

67% of Gen Z (18-26) shoppers will switch retailers for faster shipping² so consider offering customers more **next day delivery options** to improve their delivery experience and your competitiveness.

31%

of businesses will promote delivery options on their website during peak this year.³

4 in 10

large businesses plan to use more next day deliveries during peak this year.³

79%

of consumers are willing to pay up to an extra \$5 to get an item they really need delivered the next day.⁴

8 in 10

businesses say different delivery speeds are important during peak.³

If you're not prioritising delivery options, you could fall behind in the race for checkout conversions. Understand how **clear communication and fast delivery options** can enhance customer satisfaction and loyalty.

“ We offer free express shipping in December to give more people confidence that they'll get their deliveries before Christmas. Otherwise, we see a big drop in sales.

– Jordan Bruno, Marketing Director at Roogenic



Boost parcel sending efficiency

Beat the crowds when lodging your parcels at a Post Office:

- Aside from lunch hour, also avoid the 3.30pm and 5.00pm time slot. This is when most people collect their parcels from Post Offices.
- Our drivers start collecting parcels from Post Offices at 3pm so try to lodge yours before then if possible.
- Talk to your Post Office manager about organising parcel lodgement in advance.
- In the last three years, the busiest day in most Post Offices was the Monday before Christmas.



The more customers who can track their own deliveries, the fewer enquiries your business receives. That translates to a reduced customer service load and lower operational costs.

1. [Download the AusPost app](#)
2. [Use a MyPost account](#)
3. [Track without logging in](#)

¹Inside Australian Online Shopping Quarterly Update April - June 2024

²2024 Inside Australian Online Shopping Report

³Australia Post Omnibus survey, July 2024

⁴Australia Post Consumer Segmentation Research Wave 7, June 2023

Nailing

the basics

For smoother parcel
packing and sending



Best practices for best results

If it's your first peak season, these best practices will help improve your parcel sending. If you've navigated peak seasons before, these are some handy reminders.

Smart prep for smooth processing

Wrap it right

Good parcel preparation is key for getting parcels to the right facility, processed faster and delivered to customers on time.

Choose packaging that:

- ✓ Is sturdy and correctly sized to fit and protect the items inside.
- ✓ Has a matte surface in bright or light colours. Glossy packaging can easily slip off conveyor belts.
- ✓ Doesn't have any loose straps, flaps, ribbons, strings or handles that can get caught on the moving parts of our sorting machines.
- ✓ Is soft (where possible) so more parcels can fit into a plane's cargo space.



Our [packaging finder](#) can help you choose the right packaging for your business.

“ We don't overload our parcels because it can cause the labels to crease, and we make sure our branded packaging best suits the size and shape of what we're sending.

– Beth Wilson, Founder of [Saint Jack Cosmetics](#)



Labels should be:

- ✓ Printed on matte white paper with the address and barcode in black ink and free of any print lines.
- ✓ Free from damage, wrinkles and wrapping.
- ✓ Placed on the largest, flattest surface of the parcel.
- ✓ Clearly visible and not covered by strapping or tape.
- ✓ Not be wrapped around edges or over a fold or seam.

Labels should include a Smart Barcode. Australia Post Smart Barcodes will also include a Delivery Point Identifier (DPID). The DPID is a unique reference number for the delivery address which helps your parcels arrive as efficiently as possible.

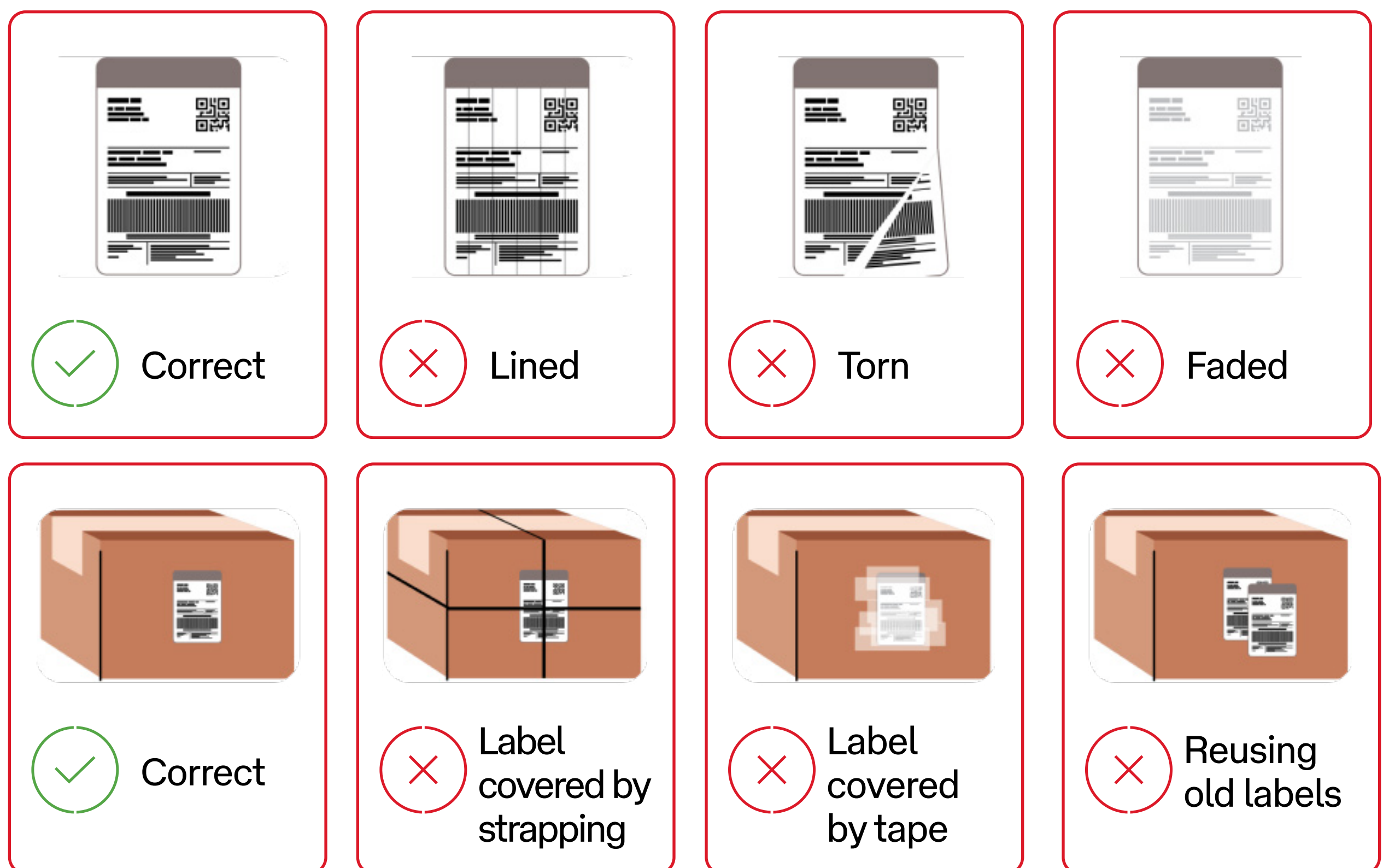

Watch our videos on best practice [packaging](#), [labelling](#) and [manifesting](#).

“ Accurate weight and size and readable barcodes are key to on-time delivery and parcel tracking. Clear barcodes are crucial because they direct each parcel through the right chute for delivery to the right location.

– Rohini Chand, Network Operations at Australia Post

Streamline your deliveries

For efficient delivery, use parcel bags to sort your parcels by:

Speed

Separate Express Post from Parcel Post so we know which parcels to prioritise. Use Express Post tape to ensure these parcels get priority.

Size

Separate small parcels from larger ones so each batch goes to the right facility. Otherwise, it'll have to be re-routed which could cause delays.



Peak season is all about business efficiency. Read how [integrating your online store with an eCommerce Partner](#) can help.

Should you be manifesting?

If you're lodging parcels at the Post Office, then you don't need to manifest and can skip this page. If you book parcel pickups, then you'll be familiar with a manifest.

Timing is everything when it comes to manifesting. Submit your manifest only when we collect your items. Too early and you set unrealistic delivery expectations. Too late and we'll need to enter data manually which causes delays.

On-time manifesting is crucial for:

- Getting parcels to customers on time.
- Parcel visibility in our network.
- Setting accurate delivery expectations.



Check parcel size and weight

To avoid any extra charges, keep your parcels within the maximum size limits for your chosen service. Also remember that boxes mustn't exceed 0.25 cubic metres.

Australia Post (Domestic)[^]

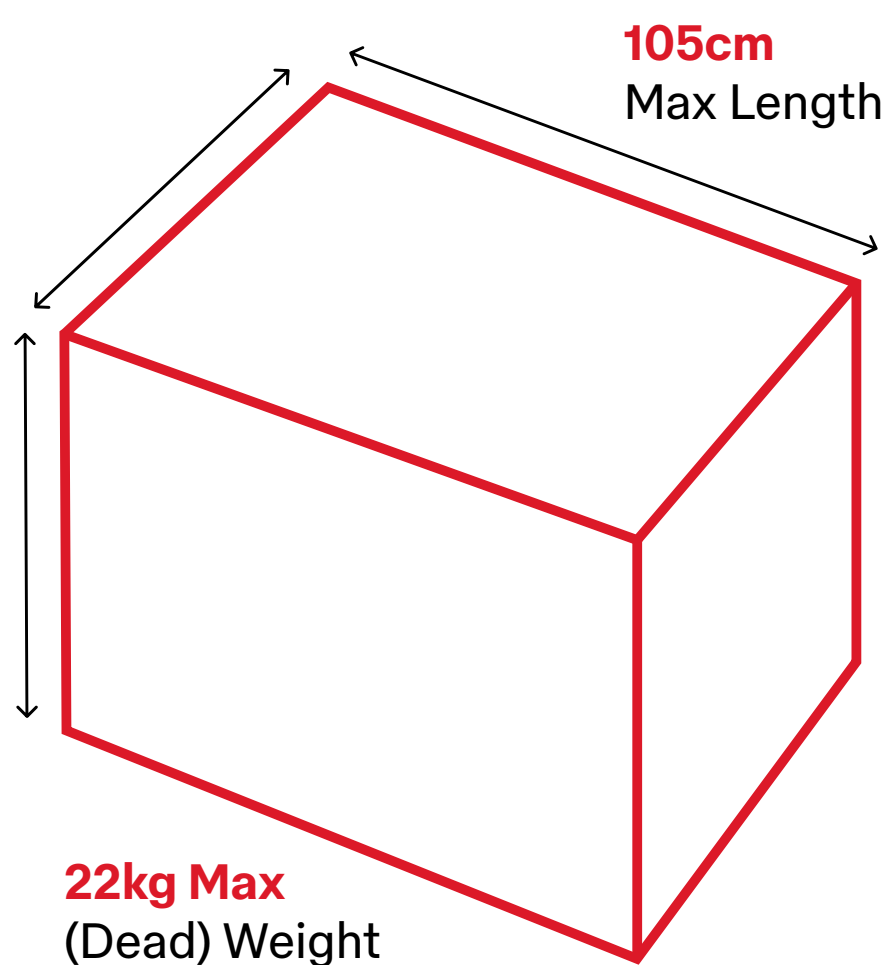

Australia Post (International)[^]

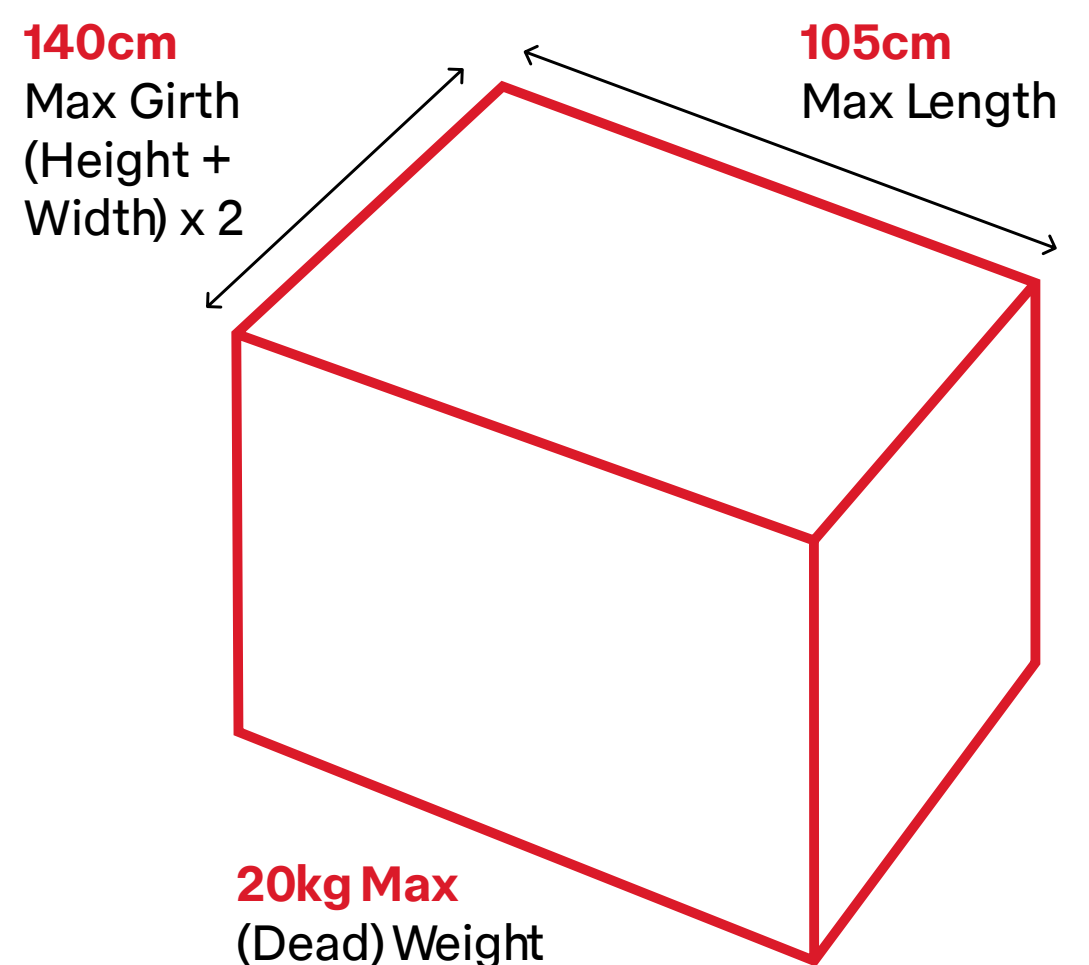

Watch our videos on best practice
[sorting](#) and [manifesting](#).

[^] Australia Post may refuse to carry any parcel that falls outside these size and weight limits and where the parcel is refused, an Administrative Fee and the Return to Sender Fee will be charged. For any parcel over the maximum limits consigned to us that does make it into our network, an Over Maximum Limits fee of \$100 (incl. GST) will be charged by Australia Post (acting reasonably having regard to the size and/or weight of the parcel), in addition to the normal delivery charge for that parcel. A Manual Handling Surcharge (MHS) will apply to any item which exceeds the StarTrack Road Express or StarTrack Premium size and weight dimensions

Hassle-free returns

Nearly

76%

of online shoppers read a website's return policy before placing an order.¹

37%

of online shoppers choose to purchase from one site over another based on the quality of the return options.²

A transparent and seamless return policy plays a subtle but important role in customers' decision-making.

A good returns policy can create an online 'fitting room' experience in your customers' home - they can try different sizes or designs, and 'put back' what doesn't suit them.

Extending returns

Consider **extending your returns policy** during peak season to 30 days or more, so gifts that are opened later can still be returned.

Free Returns

Offer free returns or returns at a simple flat rate to increase basket size and order frequency.

Reminder

Mention your returns policy on your checkout page as a friendly reminder and/or in your purchase confirmation email so customers can easily find it.

Speedy refunds

Ensure speedy refunds – either when the customer sends their return or as soon as you receive it.



Who is using returns the most?

Understanding how likely your customers are to return an item³ can help you better forecast your post-peak returns volume.

Gen Z (18-26)

51%

are riding the return wave, indicating a strong inclination for sending items back.

Gen Y (27-43)

44%

are embracing the return game, opting to send items back.

Gen X (44-59)

34%

of shoppers return items, showing some adoption of eCommerce returns in this segment.

Baby Boomers (60-78)

21%

are returning items to retailers, with the majority sticking with their purchases.

“ Consider providing a new satchel or large returns label, so the customer can cover up the original delivery address. This helps the item reach the right destination quickly and easily.

– Lin Pidding, Manager of Winston Hills LPO



Printer-less returns

With Print at Post, you can email your customers a QR code to get their returns label printed for free. All they need to do is show the code at a participating Post Office⁴ – a big timesaver for those without a home printer.



“ No one knew who we were in our first two years of business. The way we got customers was to provide a hassle-free, 100-day return policy.

– Richard Li, Co-founder of [July Luggage](#)



Watch our video on best practice [returns](#).

¹Australia Post Omnibus Consumer Survey, Nov 2023

²Australia Post Consumer Omnibus Survey, Jan 2023

³Inside Australian Online Shopping Report 2024

⁴Only available at select Post Offices. Visit our [Post Office locator](#) to search for your nearest outlet offering Print at Post.

International sending at your fingertips

Is your brand jet-setting around the world? Max Sahil, International Solutions Lead at Australia Post has these tips for a smoother sending experience.

1. Peak season

Australia Post's international peak season centres on Black Friday, with most of our deliveries being fashion items to the U.S. If this is your sector, be sure to factor in extra delivery time during this period.

2. Stay updated

Monitor [international delivery times](#) and [service updates](#) on our website so you can communicate any changes to customers.

3. Choose compact packaging

Choose packaging that's protective yet compact to maximise the number of parcels that can fit on a plane.

4. Provide details in advance

Provide the HS tariff code, addresses and postcodes in advance (even for optional fields) for items sent to Electronic Advance Data (EAD) mandated destinations and European Union (EU) countries. Submit this information through the business lodgement systems to avoid items being returned to sender.

Global opportunity

In the first quarter of 2024,
eCommerce increased

8.6%

while total retail
sales increased

1.5%

The latest U.S. eCommerce sales data suggests that Australian international selling is growing. In the first quarter of 2024, eCommerce increased 8.6% when compared with the first quarter of 2023, while total retail sales increased 1.5% in the same period.¹

However, Australia represents less than 5% of global trade, which presents a huge expansion opportunity for Aussie businesses internationally.

Australia Post international size and weight guidelines



Max. (dead) weight	20kg
Max. length, longest side	105cm
Max. girth (height + width) x2	140cm

“ Make reliability your top priority. Every dog&boy parcel has a tracker because I need to follow that parcel’s journey once it leaves Australia.

– Sonya Michele, Founder of [dog&boy](#)



Watch our videos on best practice [international sending](#).

Bookmark for quick reference:

[International export tools](#) help you classify your goods easily and accurately and understand taxes and duties that may be charged at destination Customs.*

[International postal guide](#) has the rules and guidelines for sending to a particular destination so your item arrives without delay.

[Optional extras](#) for more peace of mind when sending internationally.

[Pre-arrival clearance for EU-bound items](#) to ensure you supply the right and complete data to destination countries.

“ Include the recipient’s contact details on your lodgement form. Many businesses leave this out and that can cause delivery delays or the parcel being returned to sender.

– Glenn Faulkner, Manager of Alstonville Post Office

¹US Census Quarterly Retail E-Commerce Sales

*Only available to parcel services customers using an enabled 3rd party platform or direct API

A positive delivery experience

Save time by helping customers track their own deliveries

Parcel tracking gives shoppers more peace of mind and visibility of their parcel's journey – which means less calls to your customer service team.

Encourage customers to download the [AusPost app](#) and sign up for a [MyPost account](#), so they can:

Raise enquiries directly with Australia Post instead of your customer service team.

Track all Australia Post deliveries in one place.

Access our 4,800+ collection points,

including 24/7 Parcel Lockers. 68% of active app users have used a delivery choice option to receive their parcel.

Have confidence

that our notifications are secure, accurate and legitimate. The AusPost app's high security features mean customers can trust the notifications aren't a scam.

Manage delivery preferences,

including whether to [have a parcel left in a safe place or redirect it](#).

How to promote

the AusPost app

- ✓ On the confirmation screen at checkout
- ✓ On your shipping page
- ✓ In your FAQs, wherever you mention shipping or order tracking



The AusPost app

3.8M

Aussies used our app during peak 2023 (up 14% YoY) – a sign of its reputation as a trusted and legitimate source of notifications from Australia Post.

How different generations use the AusPost app to improve their delivery experience¹

Gen Z (18-26)

16%

add Parcel Locker locations in the app.

Gen Y (27-43)

24%

like renaming their deliveries.

Gen X (44-59)

34%

value push notifications and real-time updates.

Baby Boomers (60-78)

63%

value tracking parcels in one spot.

“ Saint Jack Cosmetics is all about providing exceptional customer service but keeping up with enquiries can be tricky during peak season. We used to receive many enquiries about parcel tracking so now we ask customers to download the AusPost app for up-to-date tracking info.

– Beth Wilson, Founder of Saint Jack Cosmetics



Parcel Lockers — a secure delivery choice

The security and convenience of Parcel Lockers offer a better delivery experience for customers who aren't always home to receive their deliveries.

More and more Australians want deliveries sent to a Parcel Locker. Offering this option could reduce customer enquiries and improve your NPS.

1.3M+

Parcel Locker deliveries during peak 2023 – up 32% YoY.

7 in 10

businesses believe it's important to offer collection points during peak.

25%

of businesses are integrating collection points on their website for peak this year.²

Here are two easy ways to add the collection points option to your website:

1. [Parcel Collections widget](#) – free to download and easy to integrate.
2. [Shopify integration](#) – via your eCommerce site.



Watch our videos on best practice [tracking](#) and [Parcel Lockers](#).



¹Inside Australian Online Shopping Report 2024

²Australia Post Omnibus survey, July 2024

The

essentials

Key details to keep you
updated and ahead



Here's how we're delivering for your business this peak

At Australia Post, we're scaling up to meet demand this peak season so we can better support your business.

We have delivered

12

new or upgraded
facilities in 2024.

We're recruiting around

3,000

seasonal casuals to boost
operations ahead of Christmas.

Up to

7 + 15

retail delivery pop-up

facilities are proposed
to uplift capacity and
service for Peak 2024.

Visit our [Peak Preparation](#) page
regularly for live updates on:

- 1 Weekend deliveries
- 2 Lodgement cut off dates
- 3 Changes to delivery times and services



Keep your website FAQs and confirmation emails up to date [using our messaging templates](#). They contain all the delivery and tracking information customers want to know.

“ This year, with Black Friday on 29 November, we expect our busiest weeks from 2-15 December. In business-to-business markets, we'll see volumes increase from early November as businesses stock up their warehouses.

– Peak Planning Team at Australia Post

Online sale event volumes skyrocketed in 2023 compared to 2019 - a prime opportunity for businesses to drive huge sales growth over just a few days.

Growth in online purchases during sales events (2023 vs 2019)

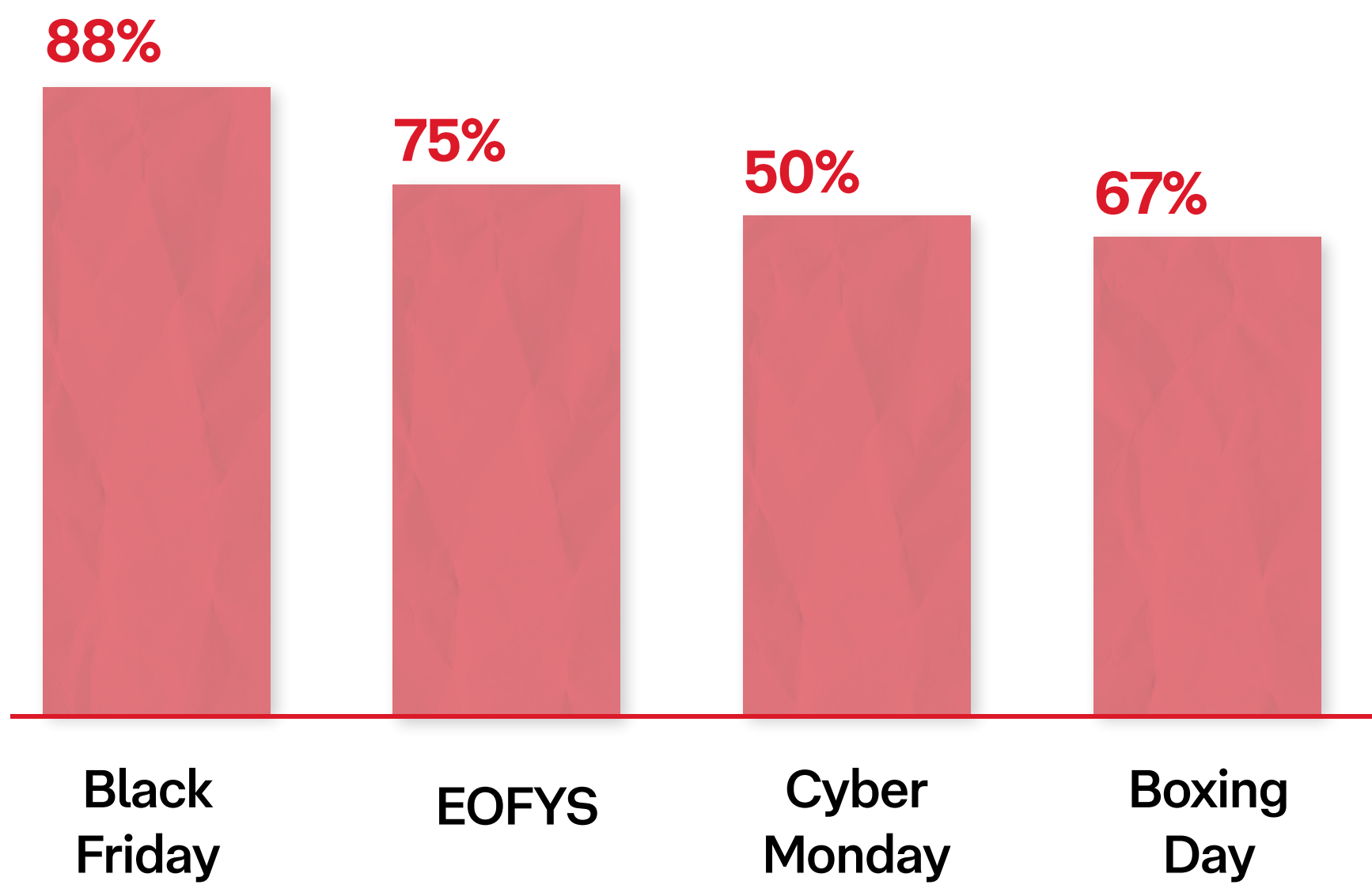

[Download our 2024 interactive eCommerce sale event calendar](#) for key sale dates, expert insights and ideas from other business to help build your sales strategy.



“ Sales events are growing in significance and will be more important given the current economic environment. Many Australians will use sales events to stretch their household budget. For example, around 10% of Australians bought Father’s Day gifts during the EOFY sales this year.

– Paul Zahra, CEO at [Australian Retailers Association](#)

Forecasting and preparing for peak season volumes

When you anticipate increases in eCommerce sales, your team can plan more effectively for on-time parcel deliveries. Here's what you could consider:

- ✓ **Develop multiple scenarios for peak season volumes**, from conservative to aggressive forecasts, so you can respond quickly to any sudden changes.
- ✓ **Tailor marketing efforts to the current economic climate**, focusing on value-driven messaging to attract budget-conscious consumers and better predict demand.
- ✓ **If you have an Australia Post Account Manager, inform them of forecast volumes early** to secure extra pickups or airline cargo space.
- ✓ **Plan around last sending dates** based on our [pre-Christmas lodgement deadlines](#).

“ **Black Friday is the biggest sale event of the year — it's when people buy Christmas presents. A big event demands a big offer and if yours isn't better than what you've had throughout the year, then you won't get noticed.**

– Beth Wilson, Founder of [Saint Jack Cosmetics](#)



Aussies spent

\$63.6B

online in 2023¹

During peak 2023

99.7M

parcels delivered to customers

These are clear indicators that eCommerce growth remains healthy despite cost-of-living concerns.



Print these [easy-to-read posters](#) for quick reference in preparing and lodging parcels correctly.



Cart abandonment can derail your peak season. Here are [eight ways](#) to create a high-converting checkout experience.



Need a question answered fast?

Save time during this busy season with our self-service tools.

eParcel Contract customers

The [Business Support Portal](#) (BSP) is the fastest and easiest way to log an enquiry on behalf of your customers. It can help you track, redirect or recall a parcel in transit, or check its status.

MyPost Business customers

Chat with a member of our team using the 'Support' tab in the [MyPost Business portal](#).* You can also create an online enquiry or call us at 13 76 78 (in Australia) or +61 3 8847 9045 (from overseas).

Contact our support team

If you prefer to speak to us, call our support team (Monday to Friday, excluding national public holidays).

- For business customers: 13 11 18 from 8am-6pm local time
- From overseas: +61 3 8847 9980 from 7am-6pm AEST



You can also [book an interpreter](#) or get 24-hour calling assistance if you're hearing or speech impaired, [details on our website](#).



Frequently asked questions

How do I track a delivery or missing item?

Find up-to-date tracking information on the BSP and MyPost Business portal. If a delivery is delayed for longer than usual, log an enquiry through either portal. You can also visit our [Peak Preparation](#) page for updates on changes to delivery times and services.

How do I access Proof of Delivery (POD)?

For eParcel customers:

- 1** Go to 'Manage your delivery' in the BSP.
- 2** Enter your tracking number, then click 'Go'.
- 3** Under 'Article events', select 'Click to view' to access Proof of Delivery. This could be an image of an item left in a safe place or a signature on delivery.

MyPost Business customers can lodge a POD request through the MyPost Business portal.

For urgent cases, call 13 11 18 (eParcel customers) or 13 11 18 (MyPost Business customers).



How do I manage my credit account?

All the [self-serve invoice and billing options](#) are available on our website. Contact details for your credit reps are at the top and bottom right-hand corners of your monthly invoice.



How do I recall a parcel in transit and redirect it to the return address?

- 1** Enter the tracking number into the 'Manage your delivery' section in the BSP.
- 2** Select 'Recall' or 'Redirect' — these options are only available if the item is eligible for a recall or redirect.

Note:

International, Post Office Box (POB), Parcel Locker and Parcel Collect articles are not eligible for this service. Also, if an item has already been attempted delivery or is awaiting collection then this service is no longer an option.

How do I track a delivery or missing item?

- To get a refund for unused labels purchased online, go to the 'Transactions' tab in your MyPost Business account and select the label you want a refund on.
- You can arrange a refund online for orders that are under 90 days old and of a value less than \$100. Charges will be refunded to your credit card or PayPal account within 5-10 business days.
- If you can't self-refund or if you used a charge account for your purchase, please contact support to process your refund.
- Merchant Portal customers can raise a refund request via the credit claim form on the Merchant Portal.

Note:

Paypal has limits on how many refunds can be processed. If you are refunding more than 25 articles from one order, please contact support to process your refund.



Simplifying eCommerce speak



Watch our [eCommerce Jargon Busters videos](#) for quick and simple explanations of terminology.

[What is DIFOT?](#)



[What is cubic weight?](#)

[What is a supply chain?](#)

[What is an HS Tariff Code?](#)

[How to offer Easy Returns?](#)

[What is flat rate packaging?](#)

[What are dangerous goods?](#)

[What is a shipping manifest?](#)



[What is a shipping platform?](#)

[What does lodgement mean?](#)

[What are Australia Post APIs?](#)

[What is authority to leave or ATL?](#)

[What is a parcel collection point?](#)

[What is an eCommerce platform?](#)

[What does Parcel Contract mean?](#)



[How do you use a prepaid satchel?](#)

[What is an eCommerce shipping integration?](#)

[What does automating shipping labels mean?](#)

[How to use Australia Post's Business Support Portal?](#)